



ExMax ¼ turn actuators – size S

Electrical, explosion proof rotary actuators with integrated Ex-i circuit (optional)
On-off control mode, 24...240 VAC/DC, 95° angle of rotation incl. 5° pretension
8 Nm, 15 Nm with safety operation: fast spring return ~ 1 s*
ATEX tested in acc. with directive 2014/34/EU for zone 1, 2, 21, 22

| |
|-------------------|
| ExMax - ... - F1 |
| ExMax - ... - SF1 |
| ExMax - ... - BF1 |
| ExMax - ... - CTS |
| ExMax - ... - VAS |

Subject to change!

Compact. Easy installation. Universal. Cost effective. Safe.

| Type | Torque | Supply | Motor running time | Spring return* | Control mode | Feedback | Wiring diagram |
|------------------|---------------------------------------------------------------------------------------------------------|-----------------|------------------------------|----------------|--------------|-------------------------------------------|------------------|
| ExMax- 8 - F1 | 8 Nm | 24...240 VAC/DC | 3 / 15 / 30 / 60 / 120 s/90° | ~ 1 s/90° | On-off | – | SB 2.4/2.5 |
| ExMax- 15 - F1 | 15 Nm | 24...240 VAC/DC | 3 / 15 / 30 / 60 / 120 s/90° | ~ 1 s/90° | On-off | – | SB 2.4/2.5 |
| ExMax- 8 - SF1 | 8 Nm | 24...240 VAC/DC | 3 / 15 / 30 / 60 / 120 s/90° | ~ 1 s/90° | On-off | 2 × aux. switches | SB 2.4/2.5 + 3.2 |
| ExMax- 15 - SF1 | 15 Nm | 24...240 VAC/DC | 3 / 15 / 30 / 60 / 120 s/90° | ~ 1 s/90° | On-off | 2 × aux. switches | SB 2.4/2.5 + 3.2 |
| ExMax- 8 - BF1 | 8 Nm | 24...240 VAC/DC | 3 / 15 / 30 / 60 / 120 s/90° | ~ 1 s/90° | On-off | 2 × aux. switches + Ex-i tripping circuit | SB 2.4/2.5 + 7.4 |
| ExMax- 15 - BF1 | 15 Nm | 24...240 VAC/DC | 3 / 15 / 30 / 60 / 120 s/90° | ~ 1 s/90° | On-off | 2 × aux. switches + Ex-i tripping circuit | SB 2.4/2.5 + 7.4 |
| ExMax- ... - CTS | Types as above with aluminium housing and seawater resistant coating (cable glands brass nickel-plated) | | | | | | |
| ExMax- ... - VAS | Types as above with stainless steel housing for aggressive ambient (cable glands brass nickel-plated) | | | | | | |

* at temperatures below -20 °C, depending on the load, the spring return period can be up to 20 sec. If fast spring return below -20 °C is required, please contact our sales support. Please note that nominal values are also subject to tolerances.

Product views and applications



Description Highlights

The ExMax actuators are a revolution for safety, control and shut-off dampers and other motorized applications for HVAC systems in chemical, pharmaceutical, industrial and offshore/onshore plants, for use in Ex-areas zone 1, 2 (gas) and zone 21, 22 (dust).
Highest protection class (ATEX) and IP66 protection, small dimensions, only 3,5 kg weight, universal functions and technical data, an integrated heater and an optional stainless steel housing guarantee safe operation even under difficult environmental conditions. High quality brushless motors guarantee long life.
All actuators are programmable and adjustable on site. Special tools or equipment are not required. Motor running times are selectable on site. The integrated universal power supply is self adaptable to input voltages in the range of 24...240 VAC/DC. The actuators are 100% overload protected and self locking.
...Max-...-F1 actuators are equipped with spring return fail safe function. Additionally the ...Max-...-SF1 and ...-BF1 actuators are equipped with 2 integrated, potential free auxiliary switches each and ...Max-...-BF1 comes with an intrinsically safe tripping circuit for connecting the ...Pro-TT-... safety temperature trigger. Standard shaft connection is a double square direct coupling with 12 × 12 mm.
Different accessories are available to adapt auxiliary switches, terminal boxes or adaptations for ball valves and throttle valves and other armatures.

- ▶ For all types of gases, mists, vapours and dusts in zones 1, 2, 21 and 22
- ▶ Universal supply unit from 24...240 VAC/DC
- ▶ 5 different motor running times 3–15–30–60–120 s/90°, adjustable on site
- ▶ On-off control with fast spring return function
- ▶ Ex-i circuit for direct connection of the ...Pro-TT-... safety temperature trigger (type ...-BF1)
- ▶ 2 integrated auxiliary switches, switching at 5° und 85° (type ...-SF1 and ...-BF1)
- ▶ 100 % overload protected
- ▶ Compact design and small dimension (L × W × H = 210 × 95 × 80 mm)
- ▶ Direct coupling to the damper shaft with double square connection 12 × 12 mm
- ▶ 95° angle of rotation inclusive 5° pretension
- ▶ Robust aluminium housing (optional with seawater resistant coating) or in stainless steel
- ▶ IP66 protection
- ▶ Simple manual override included + preparation for comfortable manual override
- ▶ Gear made of stainless steel and sinter metal
- ▶ Weight only ~ 3,5 kg
- ▶ Integrated heater for ambient temperatures down to -40 °C
- ▶ Integrated safety temperature sensor
- ▶ Integrated equipment for manual adjustment (push button, lamp, switch)
- ▶ Preparation for adaptable and adjustable auxiliary switches type ...Switch



ExMax-...-F1

ExMax-...-SF1

ExMax-...-BF1

SCHISCHEK
EXPLOSIONPROOF

Special options

... -CTS

... -VAS

| Technical data | ExMax- 8 - F1 | ExMax- 15 - F1 | ExMax-... - SF1 | ExMax-... - BF1 |
|----------------------------------|-------------------------------------------------------------------------------------------------------------------------------------------------------------------------------------|--------------------------------------------------------------------------------------------------------------------------------------------------------------------------------------------------------------------------------------------------------------------------------------------------------------------------------------------------------------------------|-----------------------------------|-----------------------------|
| Torque motor (min.) | 8 Nm | 15 Nm | 8 resp. 15 Nm | 8 resp. 15 Nm |
| Torque spring (F) | min. 8 Nm | min. 15 Nm | min. 8 resp. 15 Nm | min. 8 resp. 15 Nm |
| Torque blockade | In blockade and end positions torques are higher than above specified torques for motor and spring. | | | |
| Dimensioning of external load | Upon spring return the external load should be max. 80 % of torque spring (F), but min. 2 Nm | | | |
| Supply voltage / frequency | 24...240 VAC/DC \pm 10 %, self adaptable, frequency 50...60 Hz \pm 20 % | | | |
| Power consumption | max. starting currents see ① Extra information (in acc. with voltage, $I_{start} \gg I_{rated}$), approx. 5 W holding power, approx. 16 W for heater | | | |
| Protection class | Class I (grounded) | | | |
| Angle of rotation and indication | 95° incl. \sim 5° pretension, mechanical value indication | | | |
| Working direction | Selectable by left/right mounting to the damper/valve shaft | | | |
| Motor running times | 3 / 15 / 30 / 60 / 120 s/90° selectable on site | | | |
| 3 sec. mode – motor | In acc. with the supply voltage and external torque 3 to 4 s/90° angle of rotation | | | |
| Motor | Brushless DC motor | | | |
| Control mode | On-off | | | |
| Spring return (F) | Spring return upon voltage interruption or opening of line 3, response time up to 1 sec. after voltage interruption | | | |
| Spring return running time (F) | \sim 1 s/90° (at temperatures below -20 °C, depending on the load, the spring return period can be up to 20 s.) | | | |
| Safety operations at 1 sec. (F) | min. 1,000 acc. to construction of damper and ambient. Consider minimum external load! | | | |
| Ex-i tripping circuit | ...-BF1 | Intrinsically safe circuit to connect the ExPro-TT... safety temperature trigger directly to the actuator with M12 quick connection | | |
| Aux. switches | ...-SF1, ...-BF1 | 2 integrated auxiliary switches, switching at 5° and 85° angle of rotation, potential free. Grid fuse-protection is recommended! U_{max}/I_{max} AC = 250 V/5 A; U_{min} AC/DC = 5 V; After one-time operation with $U > 24$ V AC/DC or $I > 100$ mA: U_{min} AC/DC = 12 V U_{max}/I_{max} DC = 48 V/1 A; I_{min} AC/DC = 5 mA; I_{min} AC/DC = 100 mA | | |
| Axle of the actuator | Double square 12 x 12 mm, direct coupling, 100 % overload protected | | | |
| Electrical connection | Cable \sim 1 m, wire cross section 0.5 mm ² , equipotential bonding 4 mm ² . Connections in hazardous areas require an Ex-e terminal box! | | | |
| Diameter of cable | \sim \varnothing 6.2 mm | \sim \varnothing 6.2 mm | \sim \varnothing 6.2 + 7.4 mm | \sim \varnothing 9.3 mm |
| Cable gland | 2 cables in version ...-SF1 M16 x 1.5 mm | | | |
| Manual override | Use delivered socket wrench, max. 4 Nm | | | |
| Heater | Integrated, controlled heater for ambient temperature down to -40 °C | | | |
| Housing material | Aluminium die-cast housing, coated. Optional with seawater resistant coating (...-CTS) or stainless steel housing, № 1.4581 / UNS-J92900 / similar AISI 316Nb (...-VAS) | | | |
| Dimensions (L x W x H) | 210 x 95 x 80 mm, for diagrams see ① Extra information | | | |
| Weight | \sim 3,5 kg aluminium housing, stainless steel \sim 7 kg | | | |
| Ambients | Storage temperature -40...+70 °C, working temperature -40...+40 °C at T6 and -40...+50 °C at T5 | | | |
| Humidity | 0...90 % rH, non condensing | | | |
| Operating 3 sec. motor run time | In 3 s mode the motor will work only after 1 minute of voltage supply. While open/close operation (open voltage supply and shut it down) motor works only with speed of 15 s/90° | | | |
| \geq 15 sec. motor run time | at 15 / 30 / 60 / 120 s 100 % of ED is permitted (ED = duty cycle) | | | |
| Maintenance | Maintenance free relative to function, maintenance must comply with regional standards, rules and regulations | | | |
| Wiring diagrams | SB 2.4/2.5 | SB 2.4/2.5 | SB 2.4/2.5 + 3.2 | SB 2.4/2.5 + 7.4 |
| Scope of delivery | Actuator, 4 screws M4 x 100 mm, 4 nuts M4, Allen key for simple manual override | | | |
| Parameter at delivery | 8 Nm, 30 s/90° | 15 Nm, 30 s/90° | 8 resp. 15 Nm, 30 s/90° | 8 resp. 15 Nm, 30 s/90° |

Approbations

| | | | |
|---------------------|-----------------------------------------------|-----------------------|----------------------------|
| ATEX Directive | 2014/34/EU | CE Marking | CE 0158 |
| EU-Type Examination | EPS 17 ATEX 1 132 X | EMC Directive | 2014/30/EU |
| IECEX Conformity | IECEX EPS 17.0065X | Low Voltage Directive | 2014/35/EU |
| Marking Gases | II 2 (2) G Ex db [ib Gb] IIC T6, T5 Gb | Enclosure Protection | IP66 in acc. with EN 60529 |
| Types ...-CTS | II 2 (2) G Ex db [ib Gb] IIB T6, T5 Gb | | |
| Marking Dusts | II 2 (2) D Ex tb [ib Db] IIIC T80°C, T95°C Db | | |
| Ex-i circuit data | see table (T 1.0) | | |

ExMax-S-F1_en
V07 - 19-Oct-2021

Schischek GmbH Germany, Muehlsteig 45, Gewerbegebiet Sued 5, 90579 Langenzenn, Tel. +49 9101 9081-0, Fax +49 9101 9081-77, E-Mail info@schischek.com



Electrical connection

All actuators are equipped with a universal supply unit working at a voltage range from 24...240 VAC/DC. The supply unit is self adjusting to the connected voltage!

The safety operation of the spring return function works if the supply voltage is cut or line 3 opened. For electrical connection inside hazardous areas an Ex-e terminal box, certificated in acc. with ATEX is required (e.g. ExBox).

An over-current protection fuse < 10 A has to be provided by installer.

Note: the initial current is appr. 2 A for 1 second.

Integrated auxiliary switches signal the rotation angle's position. U_{min} and I_{min} change once the switches were operated with higher voltage or current.

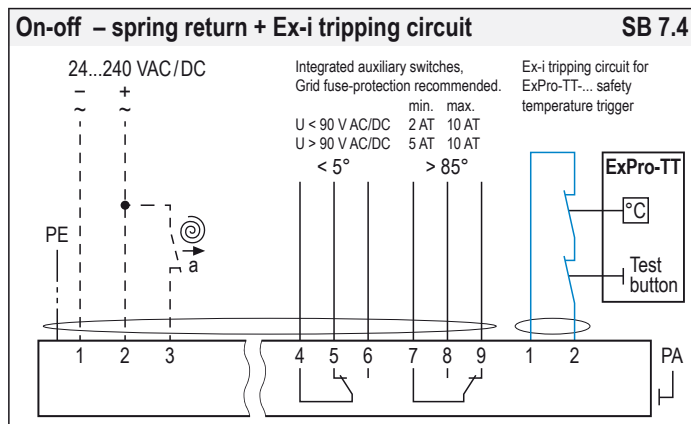
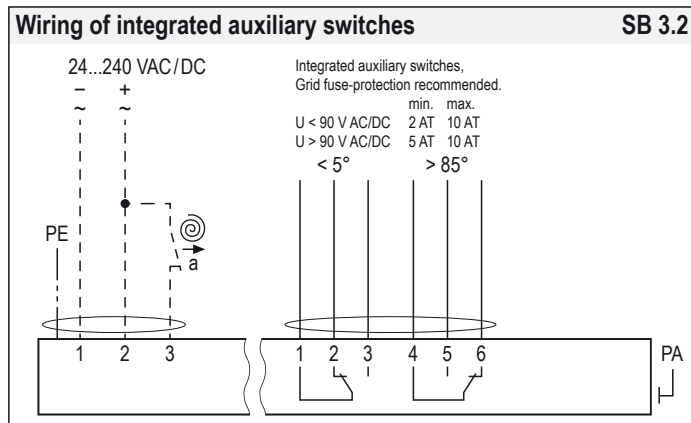
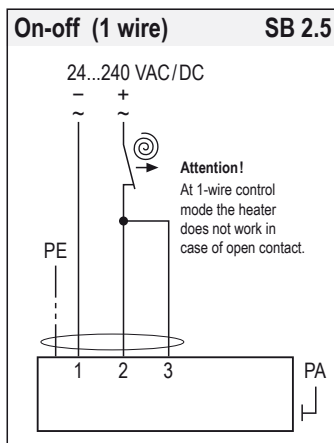
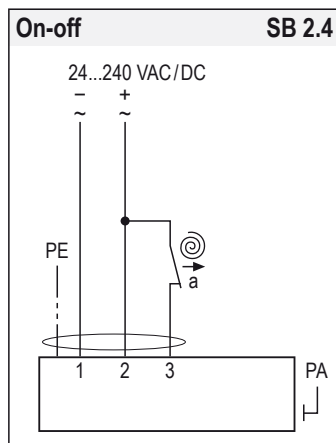

Ex-i intrinsic safe data – for temperature trigger ExPro-TT T 1.0

$U_o = 5,88 \text{ V}$
 $I_o = 24,75 \text{ mA}$
 $P_o = 37 \text{ mW}$
 $C_i = 0$
 $L_i = 0$

| | IIC | IIB | IIA |
|-------|------------------|--------------------|--------------------|
| L_o | 50 mH | 50 mH | 50 mH |
| C_o | 43 μF | 1000 μF | 1000 μF |

Parameters, adjustments and failure indication

Switch – Push button – Lamp for adjustment (behind the blanking plug)

10-position switch (S)
 Push button (T)
 3-colour LED

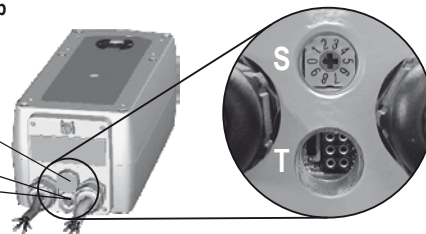

Parameter selection

Example:
 ExMax-15-BF1

Requested parameter:
 Torque 15 Nm
 Motor running time 30 s/90°

| Type | Torques | |
|------------------|------------------------|--------------|
| ExMax- 8 -...F1 | ▶ | 8 Nm |
| ExMax- 15 -...F1 | ▶ | 15 Nm |
| | ▼ | |
| Running times | Position of switch (S) | |
| 3 s/90° | ▶ | 00 05 |
| 15 s/90° | ▶ | 01 06 |
| 30 s/90° | ▶ | 02 07 |
| 60 s/90° | ▶ | 03 08 |
| 120 s/90° | ▶ | 04 09 |

Result:
 Switch position **02**

Functions, adjustments and parameters

A) Self adjustment of angle of rotation

ATTENTION: To adjust the angle of rotation connect only wire 1 and 2. Do not connect wire 3.

Apply supply voltage to wire 1 and 2. Turn switch (S) to position 02. Press button (T) for a minimum of 3 seconds. The actuator drives to the first end position, detects the blocking position and performs a spring return to the starting position. The LED flashes GREEN during adjustment. After that disconnect from the mains and connect wire 3.

The adjustment takes about 31 seconds (30 sec. "On", 1 sec. "Off").

B) Selecting motor running time

Adjust parameters only if actuator is in idle state or without applied potential.

Turn switch (S) to the position required for the intended operation acc. to table above. The selected parameters will be carried out at the actuator's next operation.

C) Function of the ExPro-TT... in the Ex-i tripping circuit

When the ...Pro-TT's tripping circuit is opened the actuator runs into its end position with spring return.

D) Additional information for control in On-off operation

a closed = actuator opens
 a open = spring return

The rotation direction (clockwise/counter clockwise) depends on left/right mounting of the actuator to the damper.

Installation

Ex area –
 zone 1, 2, 21, 22



Safe area



ExBox

Auxiliary switches *
 see Technical data

Supply *
 24...240 VAC/DC $\pm 10 \%$

* electrical wiring see diagrams



Attention

During commissioning apply a self adjustment drive.
 Regard duty cycle at motor running times!
 Never use spring return actuators without external load.



Important information for installation and operation

A. Installation, commissioning, maintenance

All national and international standards, rules and regulations for hazardous Ex-areas must be complied with. Certified apparatus must be installed in accordance with manufacturer instructions. If the equipment is used in a manner not specified by the manufacturer, the safety protection provided by the equipment may be impaired. For electrical installations design, selection and erection, EN/IEC 60079-14 can be used. For electrical connection an Ex-e terminal box is required (e.g. ExBox-...).

Attention: If the actuator is put out of operation all Ex rules and regulations must be applied. You have to cut the supply voltage before opening the terminal box!

The cables of the actuator must be installed in a fixed position and protected against mechanical and thermal damage. Connect potential earth. Avoid temperature transfer from armature to actuator! Close all openings with min. IP66. For outdoor installation a protective weather shield against sun, rain and snow should be applied to the actuator as well as a constant supply at terminal 1 and 2 for the integrated heater. During commissioning apply a self adjustment drive. Actuators are maintenance free. An annual inspection is recommended. For electrical installations inspection and maintenance, EN/IEC 60079-17 can be used. Ex-actuators must not be opened by the customer.

B. Manual override

Manual override only if supply voltage is cut. Use delivered socket wrench with slow motions, usage can be tight.

Attention: Releasing or letting go the Allen key too fast at manual operating actuators with spring return causes risk of injury!

C. Shaft connection, selection of running time

Actuators are equipped with a direct coupling double square shaft connection of 12 x 12 mm. For round shafts adaptors/clamping connection (accessories, e.g. KB-S) are available. The housing of the actuator is axially symmetrically built to select Open-close direction of the spring return function by left-right mounting. Using the 10-position switch different motor running times and spring return running times can be selected on site in acc. to the actuator type.

D. Temperature trigger ...Pro-TT-...

The actuator ...Max-...-BF1 will work only with the temperature trigger ExPro-TT-...

E. Operation with 3 sec. motor running time

Note following:

1. The 3 sec. motor running time mode is only available in switch position 0 and 5 and at a constant supply voltage applied for a minimum of 1 minute on terminal 1 and 2.
2. The actuator opens at voltage on terminal 3 (resp. closes) and closes at voltage on terminal 4 (resp. opens) – depending on mounting position of the actuator.
3. The max. duty ratio is 10 % resp. 1 cycle/minute. Between two fully 3 sec. cycles in the same direction there must be a minimum intermission of 1 minute. Trying to run the actuator in the same direction in less than the required minimum of 1 minute the function will be blocked for the rest of the idle period. Later the release for the next cycle is made automatically by an internal timing relay.
4. Same function is applied on spring return actuators, fail safe operation is regarded same as a motor running cycle.
5. Trying to use the 1 wire On-off method in switch position 0 and 5, software changes the motor running time temporarily and automatically to 15 s/90° to protect the actuator for overheating due to uncontrolled duty ratio.

F. Spring return

Spring return function works only if the supply voltage for terminal 1 or 2 is cut. In the event of an electrical interruption, the spring returns to its end position even if supply voltage is available again during return function. Thereafter operation will continue.

G. Operation at ambient temperatures below -20 °C

All actuators are equipped with a regulated integrated heating device designed for employments down to -40 °C ambient temperature. The heater will be supplied automatically by connecting the constant voltage supply on the clamps 1 and 2.

1. After mounting the actuator must be immediately electrically connected.
2. The heater switches on automatically when actuator reaches internally -20 °C. It heats up the actuator to a proper working temperature, then heater switches off automatically. Actuator will not run during heating process.
3. The adjustment options are only ensured after this heating up period.

H. Excess temperatures

In acc. to the ATEX rules and regulations Ex actuators must be protected against excess temperature. The internal thermostat works as a maximum limiter and, in the event of failure at incorrect temperatures, shuts off the actuator irreversible. An upstream connected temperature sensor stops the actuator before reaching its max. temperature. This safety feature is reversible, after cooling down the actuator is completely functional again. In this case the failure must be eliminated immediately on site!

I. Synchron mode

Do not connect several actuators to one shaft or link mechanically together.

J. Mechanical protection

Actuators must be operated with a minimum external load.

After installing the actuator to the damper/armature a self adjustment drive has to be performed in order to protect the damper/armature against mechanical overload. During operation the actuator reduces briefly its speed (motor power) before reaching the end position for a "gentle" blockade/stop.

K. Intrinsically safe circuits

The actuator has a flameproof enclosure acc. to EN 60079. The supply of the push button (adjustment drive), the 10-position switch (adjustment of torque and running time), the LED indicator and the sensor connection ExPro-TT is performed intrinsically safe!

L. Routine tests of fire dampers

For periodic inspection of fire dampers cut off the supply line (current of actuator). The test button at ExPro-TT-... is only used for test purposes of actuator's function.

ⓘ Extra information (see additional data sheet)

Additional technical information, dimensions, installation instruction, illustration and failure indication

Special solutions and accessories

...-CTS Types in aluminium housing with seawater resistant coating

...-VAS Types in stainless steel housing, parts nickel-plated

Adaptions for dampers and valves on request

ExMax-...-S3 Ambient temperature up to +60 °C (T4), 110...240 VAC/DC, 25 % ED

ExPro-TT-... Safety temperature trigger for fire dampers

ExBox-... Ex-e terminal boxes for zone 1, 2, 21, 22

MKK-S Mounting bracket for boxes type ...Box-... directly on actuator

ExSwitch 2 external aux. switches, adjustable for zone 1, 2, 21, 22

KB-S Clamp for damper shafts Ø 10...20 mm and □ 10...16 mm

AR-12-xx Reduction part for 12 mm square connection to 11, 10, 9 or 8 mm shafts

BSH-S Mounting holder for actuators in fire danger areas

Kit-S8 Cable glands nickel-plated