

Switching Power Supply S8PS

Compact DIN-Rail Mounting Industrial Power Supplies with Capacities Up to 600 W

- Models range from 50 W to 600 W.
- Universal input: voltage range 100 to 240 VAC.
- Power Factor Correction (PFC) on all models.
- UL508 approval on 100-W and 150-W models.
- DIN-rail mounting brackets provided (except with 600-W model).
- Protection-ON alarm indicators (300-W and 600-W models).
- UL, CSA, VDE, and CE approved.
- 3-year warranty.



Ordering Information

Stock Note: Shaded models are normally stocked.

■ OPEN-FRAME TYPE

Rated input voltage	Power ratings	Output		Part number	
		Voltage	Current	Front-mounting bracket	DIN-rail mounting bracket
100 to 240 VAC	50 W	5 V	10 A	S8PS-05005	S8PS-05005D
		12 V	4.2 A	S8PS-05012	S8PS-05012D
		24 V	2.1 A	S8PS-05024	S8PS-05024D
	100 W	24 V	4.5 A	S8PS-10024	S8PS-10024D
	150 W	24 V	6.5 A	S8PS-15024	S8PS-15024D

■ COVERED TYPE

Stock Note: Shaded models are normally stocked.

Rated input voltage	Power ratings	Output		Part number	
		Voltage	Current	Front-mounting bracket	DIN-rail mounting bracket
100 to 240 VAC	50 W	5 V	10 A	S8PS-05005C	S8PS-05005CD
		12 V	4.2 A	S8PS-05012C	S8PS-05012CD
		24 V	2.1 A	S8PS-05024C	S8PS-05024CD
	100 W	24 V	4.5 A	S8PS-10024C	S8PS-10024CD
	150 W	24 V	6.5 A	S8PS-15024C	S8PS-15024CD

■ ENCLOSED TYPE

Stock Note: Shaded models are normally stocked.

Rated input voltage	Power ratings	Output		Part number	
		Voltage	Current	Front-mounting bracket	DIN-rail mounting bracket
100 to 240 VAC	300 W	24 V	14 A	S8PS-30024C	S8PS-30024CD
	600 W	24 V	27 A	S8PS-60024C	---

■ MODEL NUMBER LEGEND

S8PS-
 1 2 3

1. Power Ratings

- 050: 50 W
- 100: 100 W
- 150: 150 W
- 300: 300 W
- 600: 600 W

2. Output Voltage

- 05: 5 V
- 12: 12 V
- 24: 24 V

3. Configuration

- C: Covered type with Front-mounting Bracket
- D: Open-frame type with DIN Rail Mounting Bracket
- CD: Covered type with DIN Rail Mounting Bracket
- None: Open-frame type with Front-mounting Bracket

■ ACCESSORIES (SOLD SEPARATELY)

Stock Note: Shaded models are normally stocked.

Description	Length	Width	Part number
DIN-rail (See <i>Dimensions</i> section for details.)	0.5 m (1.64 ft)	7.3 mm (0.29 in)	PFP-50N
	1 m (3.28 ft)	7.3 mm (0.29 in)	PFP-100N
	1 m (3.28 ft)	16 mm (0.63 in)	PFP-100N2

Specifications

Item	50 W	100 W	150 W	300 W	600 W
Efficiency (typical)	74 to 80% (depends on the model)				
Life expectancy (See Note 3.)	10 yrs. min. (used at 40°C at the rated input with a 50% load, standard installation)				
Input					
Voltage	100 to 240 VAC (85 to 264 VAC)				
Frequency	47 to 63 Hz				
Current (See Note 1.)	0.9 or 0.45 A max.	1.8 or 0.9 A max.	2.7 or 1.4 A max.	5.4 or 2.7 A max.	10 or 5 A max.
Power factor (See Note 1.)	0.95 TYP.				
Leakage current (See Note 1.)	0.5 or 1.0 mA max.				
Inrush current (25°C, cold start) (See Note 1.)	25 or 50 A max.				

(This table continues on the next page.)

- Note: 1. 100% load for rated input voltage (100 VAC or 200 VAC)
2. Mean Time Between Failures is calculated according to the probability of accidental device failures, and indicates reliability of devices. Therefore, it does not necessarily represent a life of the product.
3. The life expectancy shown in the above table indicates average operating hours under the ambient temperature of 40°C and a load rate of 50%. Normally this is determined by the life expectancy of the built-in aluminum electrolytic capacitor. It must be noted that the life expectancy of the fan built into the 600-W model is not included.
4. The weight indicated is for the open-frame type. (Includes the cover for 300-W and 600-W models.)

Engineering Data

DERATING CURVE

Open-frame Type

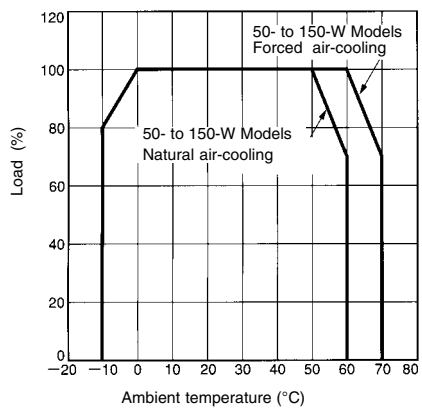

Covered Type

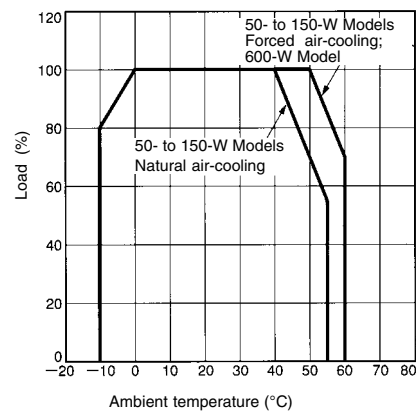

- Note: 1. The derating curve shown is for standard installation. The derating curve depends on mounting direction of the Power Supply.
 2. Forced air-cooling must be provided with an air volume of 1 m³/min.

STANDARD INSTALLATION

50-W Type

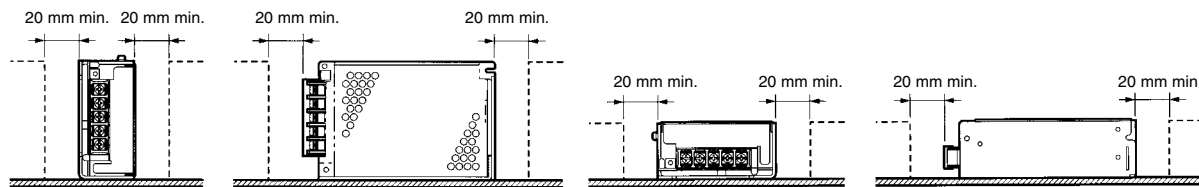

100/150-W Type

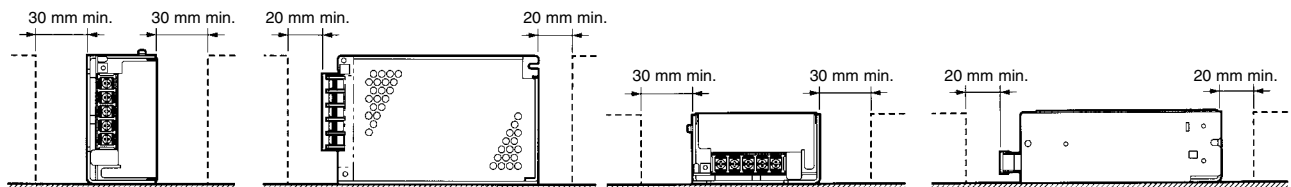

300-W Type

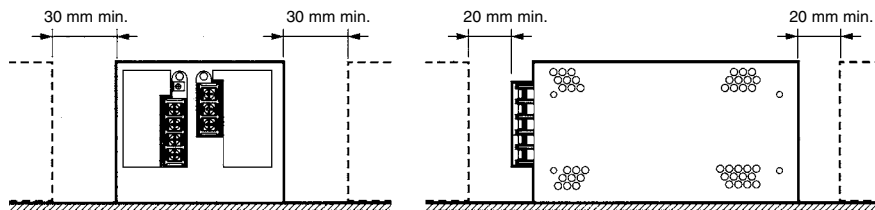

600-W Type

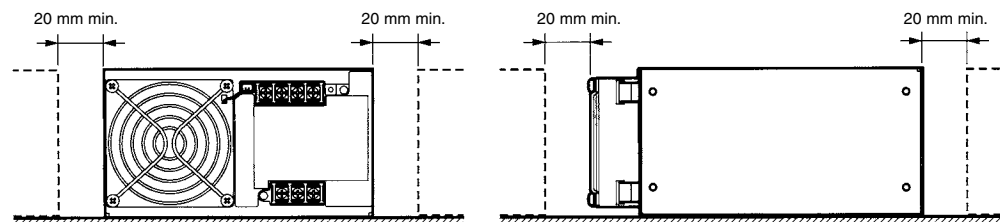

OVERLOAD PROTECTION

50- to 300-W Models

The Power Supply has an overload protection function that protects the load and the power supply from possible damage by overcurrent. When the output current rises above a set value (105% of the rated output current), the protection function is triggered, decreasing the output voltage. When the output current falls within the rated range, the overload protection function is automatically cleared.

600-W Models

If an excessive current flows for 5 s or more, the output will be turned OFF and simultaneously protection-ON alarm indicator will be lit. To reset the S8PS, turn OFF the input voltage, leave the S8PS for at least three minutes, and then apply the input voltage again.

Note: Do not continue using the S8PS with the output terminals short-circuited or the overcurrent condition continued, otherwise the internal elements of the S8PS may be damaged or broken.

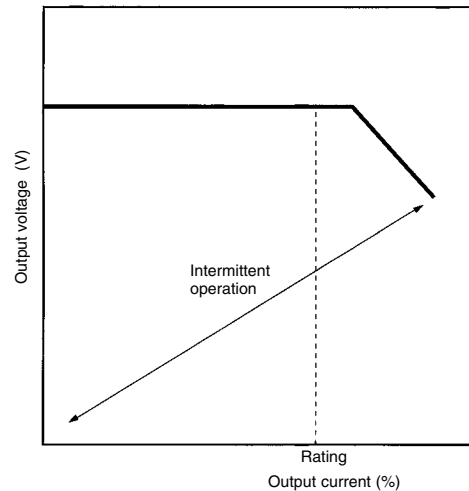

OVERVOLTAGE PROTECTION

The Power Supply has an overvoltage protection function that protects the load and the Power Supply from possible damage by overvoltage. When the output voltage rises above a set value (120% of the rated output voltage), the protection function is triggered, shutting OFF the output voltage. If this occurs, reset the Power Supply by turning it OFF for 1 minute min. and then turning it ON again.

300- and 600-W Models

If voltage that is 115% of the rated output voltage or above is output, the output voltage will be turned OFF and simultaneously protection-ON alarm indicator will be lit. To reset the S8PS, turn OFF the input voltage, leave the S8PS for at least one minute and then apply the input voltage again.

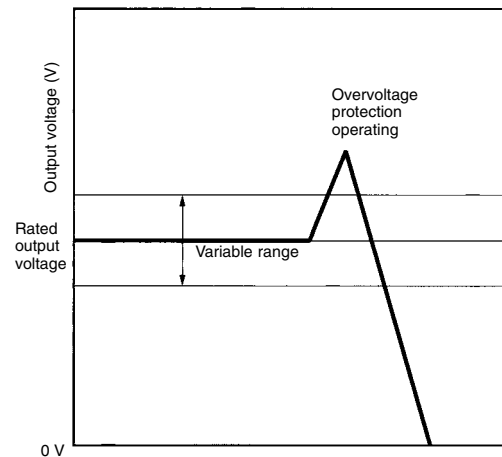

OVERHEAT PROTECTION FUNCTION

600-W Model Only

If the internal temperature of the S8PS rises excessively as a result of fan failure or any other reason, the overheat protection circuit will be triggered to protect the internal elements of the S8PS and simultaneously a protection-ON alarm indicator will be lit. To reset the S8PS turn OFF the input voltage, leave the S8PS for at least one minute and then apply the input voltage again.

■ INRUSH CURRENT, START UP TIME, HOLD TIME

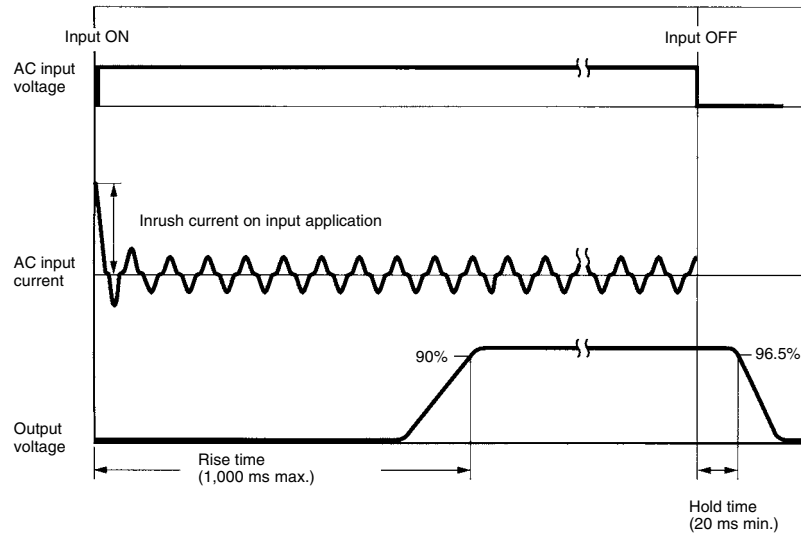

Operation

■ BLOCK DIAGRAMS

S8PS-050□□□□ (50 W)

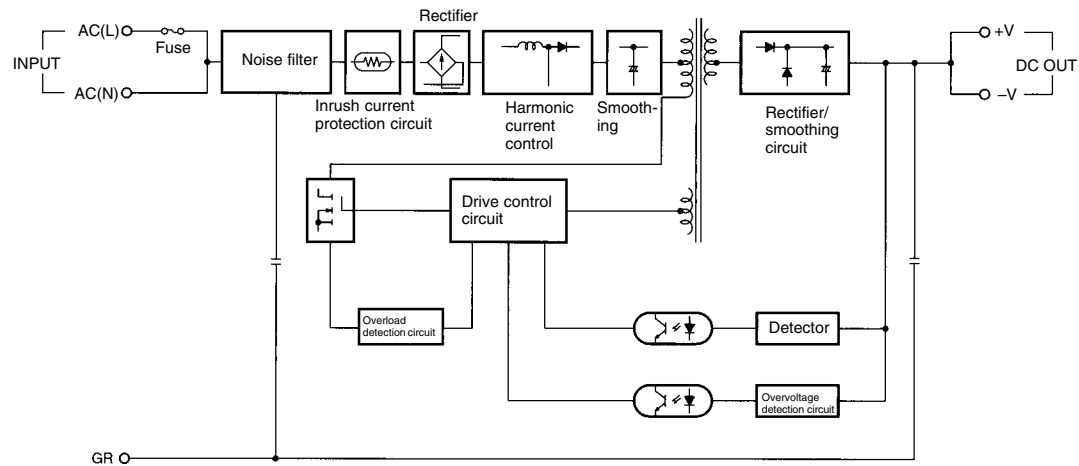

S8PS-10024 □ □ (100 W)
 S8PS-15024 □ □ (150 W)
 S8PS-30024 □ □ (300 W)

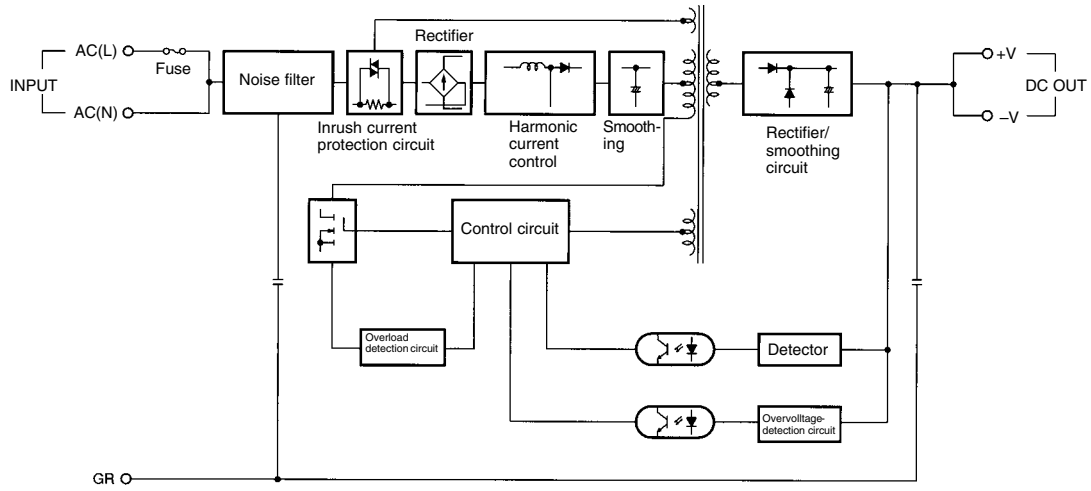

S8PS-60024C (600 W)

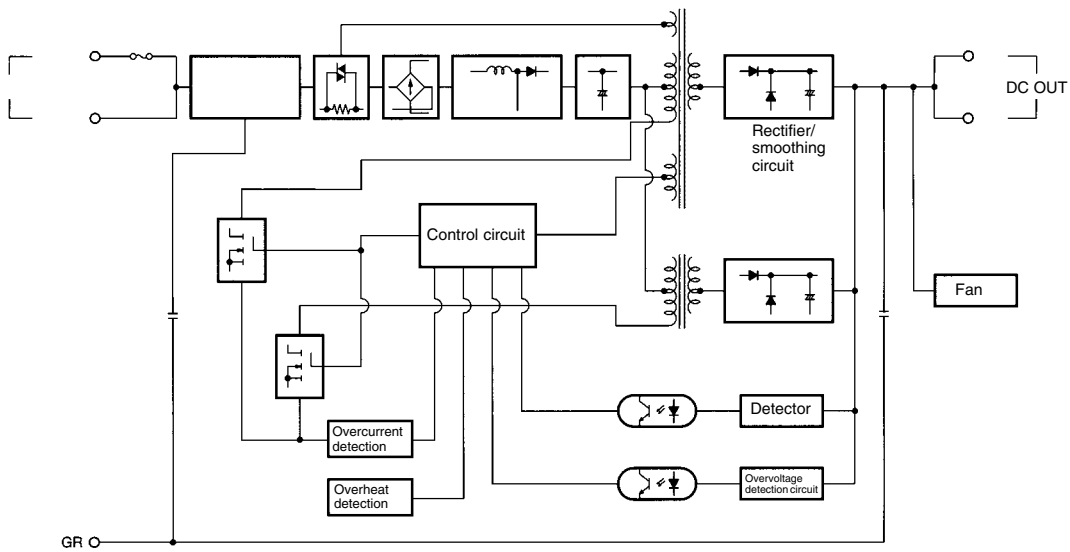

Dimensions

Unit: mm (inch)

FRONT-MOUNTING BRACKET TYPE

Note: For instructions on how to install the front-mounting brackets, refer to the a subsequent section: *FRONT-MOUNTING BRACKETS*.

S8PS-050□□ (50 W)
S8PS-050□□C (50 W)

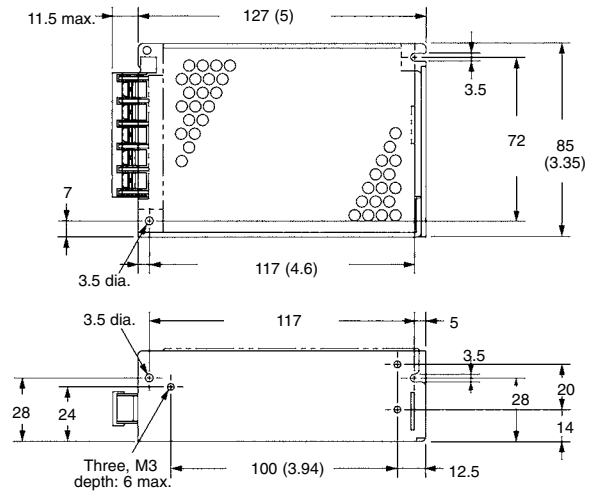
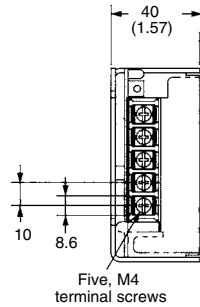
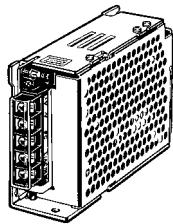

S8PS-10024 (100 W)
S8PS-10024C (100 W)

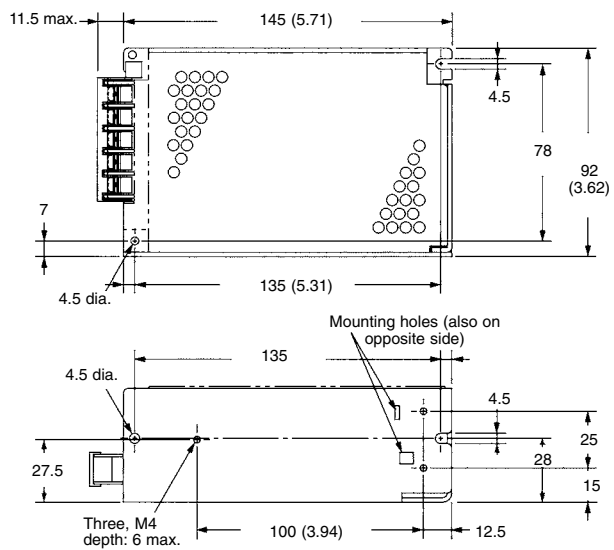
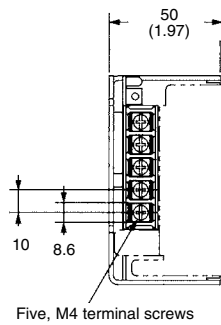
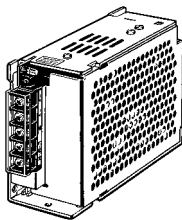

S8PS-15024 (150 W)
S8PS-15024C (150 W)

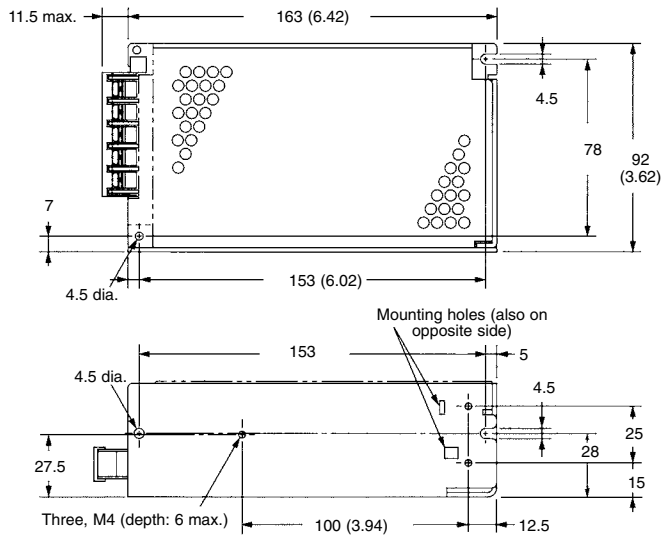
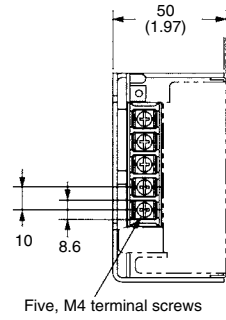
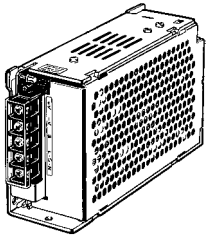

S8PS-30024C (300 W)

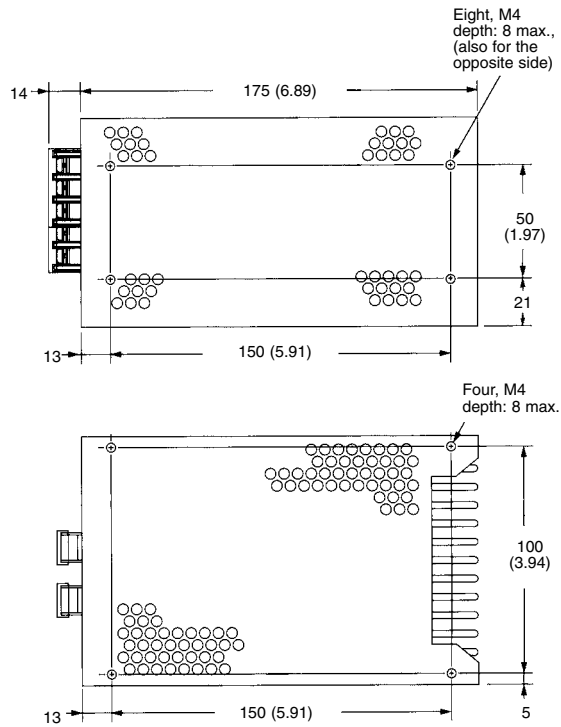
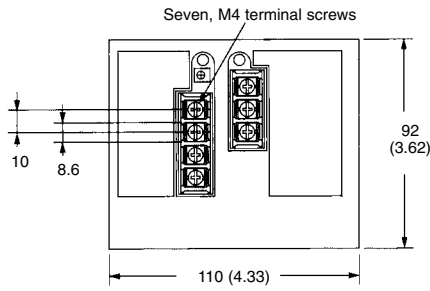
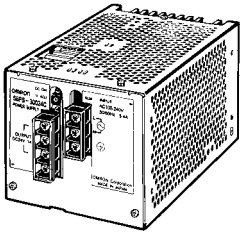

Unit: mm (inch)

S8PS-60024C (600 W)

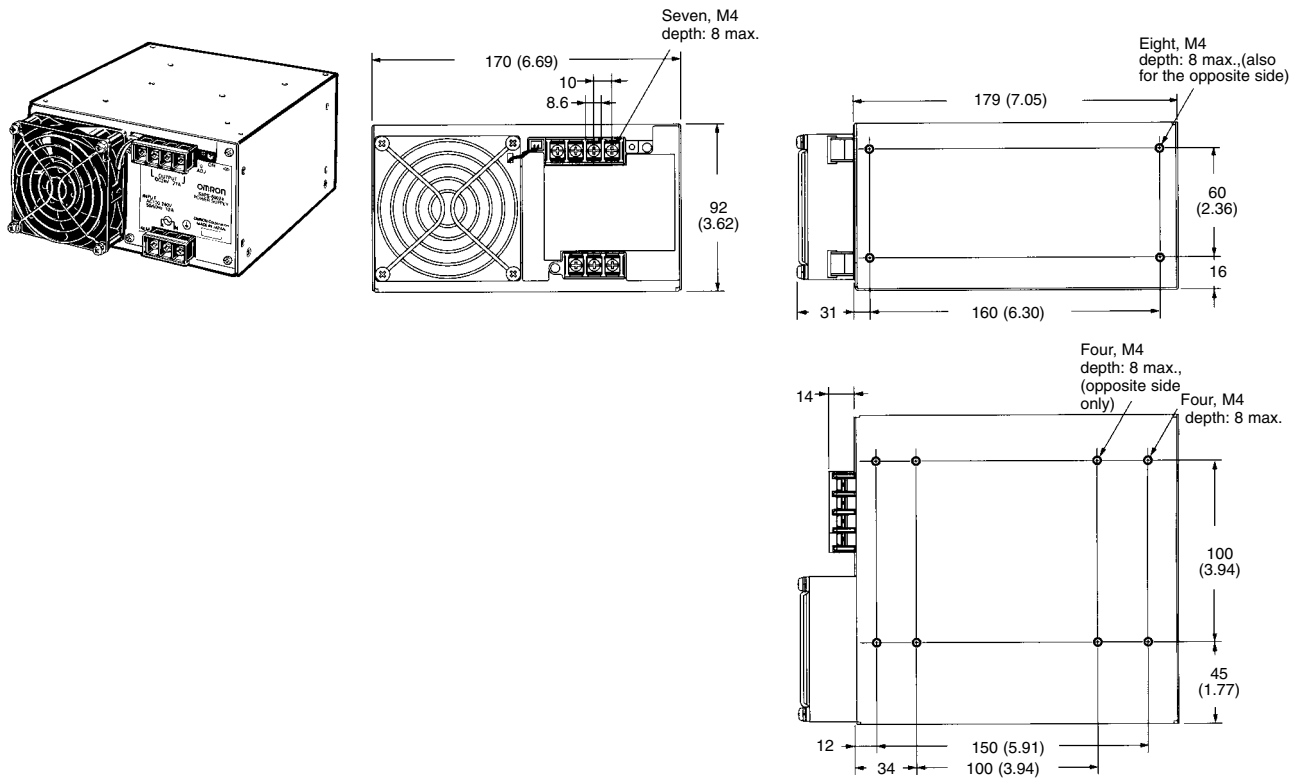

■ **FRONT-MOUNTING BRACKETS**

50-W Models

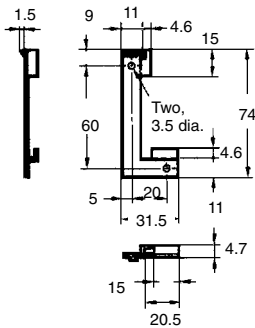

Using the Mounting Bracket

Attach the Mounting Bracket to the panel and loosely tighten the two screws. Insert the projected parts of the Bracket (b) to the square holes of the power supply (a). Then securely tighten the screws.

Mounting Holes

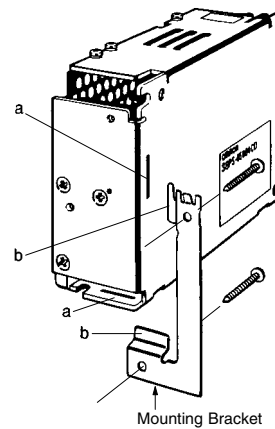
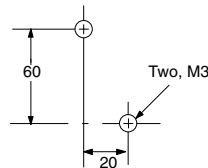

100/150-W Models
Appearance and Mounting Dimensions

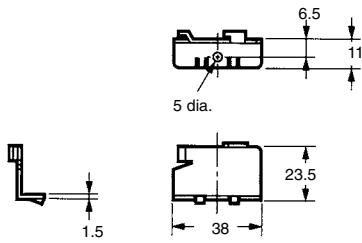

Dimensions with Mounting Bracket

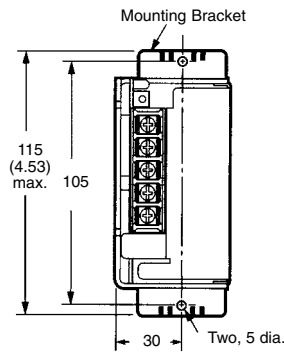

Using the Mounting Bracket

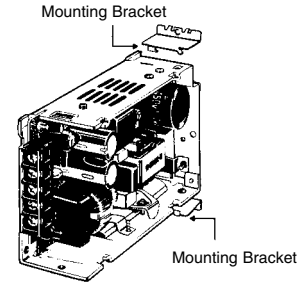

300/600-W Models
Appearance and Mounting Dimensions

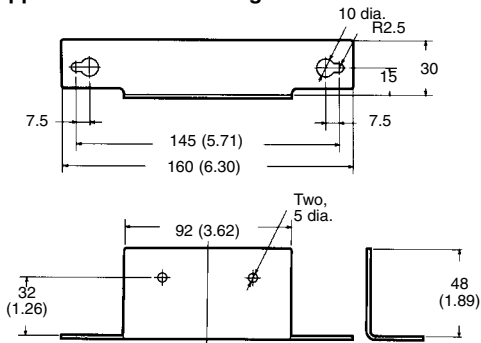

Dimensions with Mounting Bracket – 300-W models

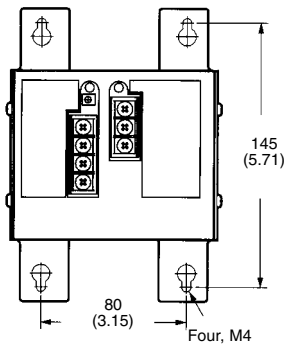

Using the Mounting Bracket

Note: Mounting screws for the Power Supply Unit are provided.

300-W models

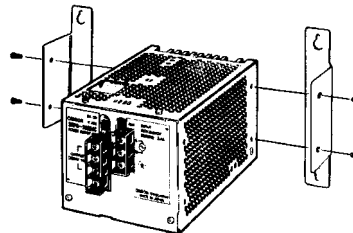

Note: Mount the Unit 21.6 mm away from the mounting surface in order to provide air ventilation on the rear side.

Dimensions with Mounting Bracket – 600-W models

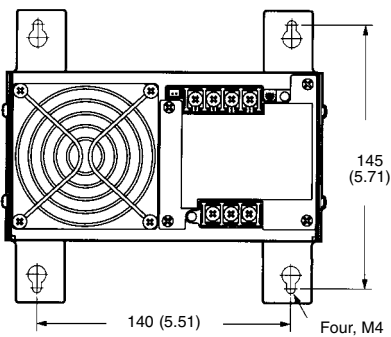

600-W models

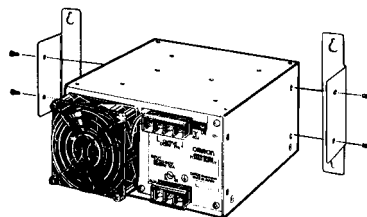

Note: Mount the Unit 28 mm away from the mounting surface in order to provide air ventilation on the rear side.

■ DIN-RAIL MOUNTING TYPE

Note: DIN-Rail Mounting Bracket is attached to the Power Supply Unit when the Unit is shipped.

S8PS-050□□D (50 W)
S8PS-050□□CD (50 W)

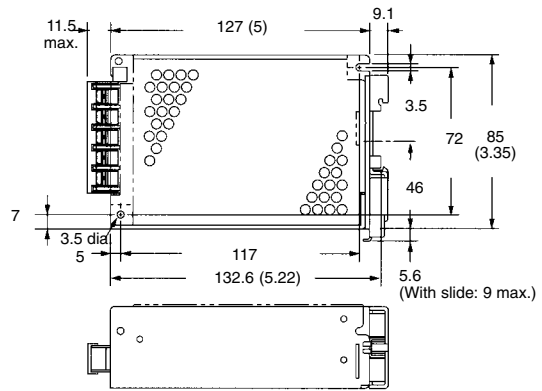
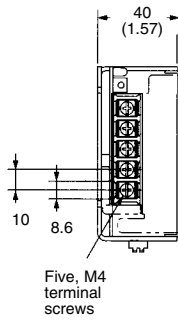
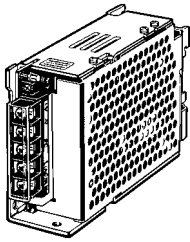

S8PS-10024D (100 W)
S8PS-10024CD (100 W)

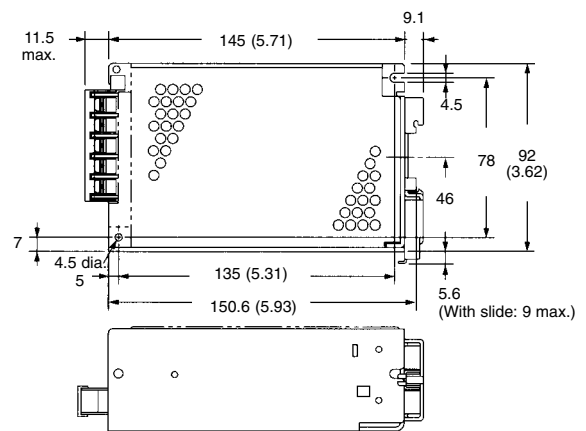
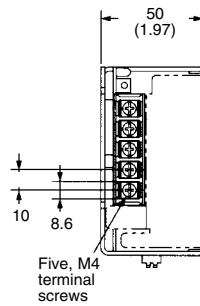
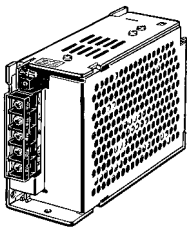

S8PS-15024D (150 W)
S8PS-15024CD (150 W)

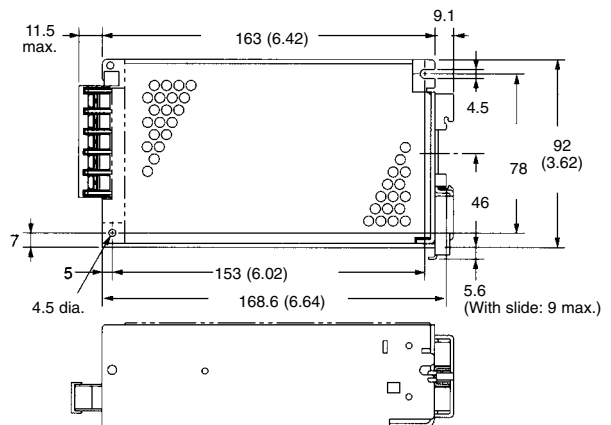
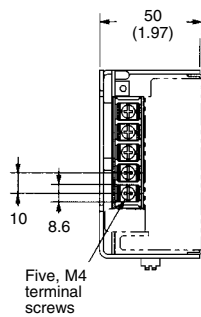
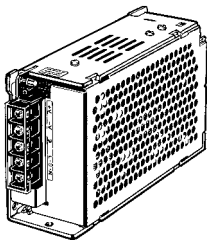

Unit: mm (inch)

S8PS-30024CD (300 W)

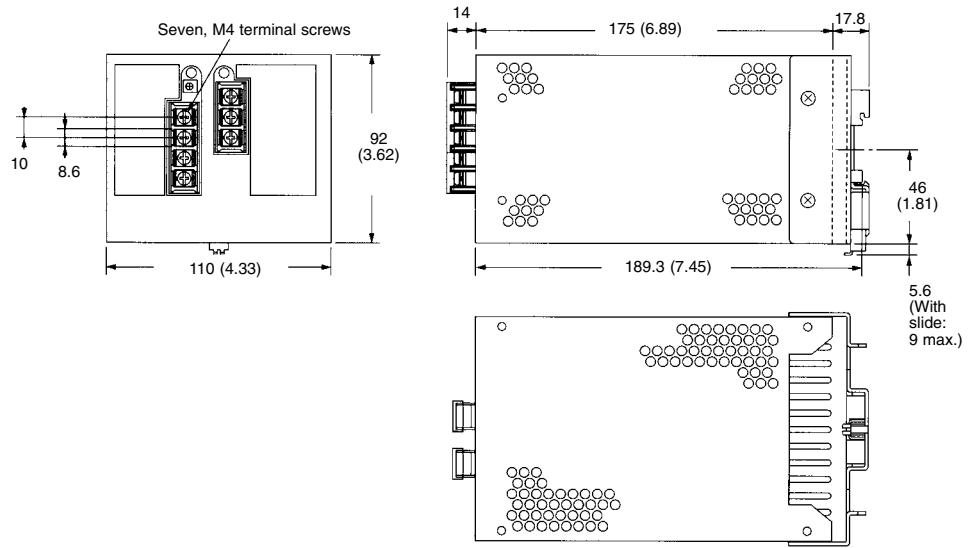
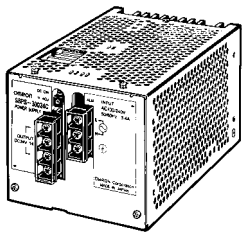

■ **DIN-RAIL (ORDER SEPARATELY)**

**PFP-100N/
PFP-50N**

PFP-100N2

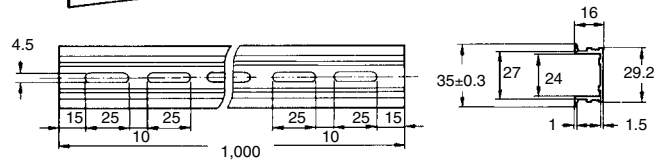
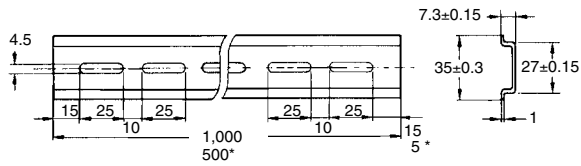
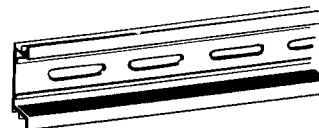
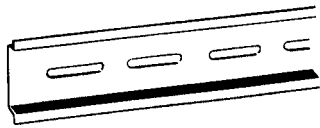

* For PFP-50N

Installation

■ 50-W MODELS

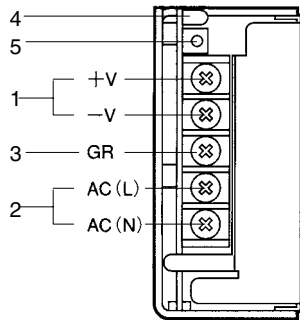

■ 100-/150-W MODELS

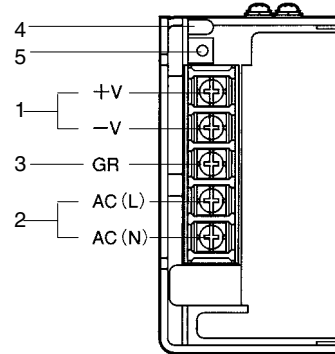

■ 300-W MODELS

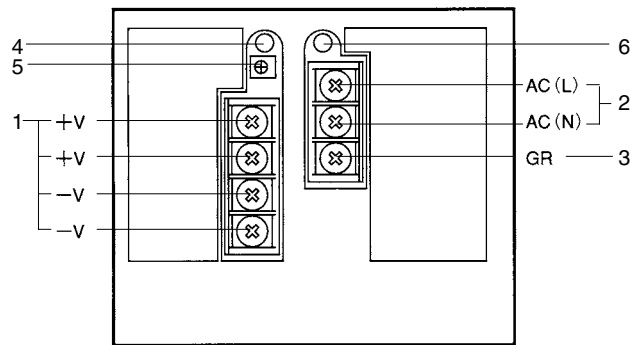

■ 600-W MODELS

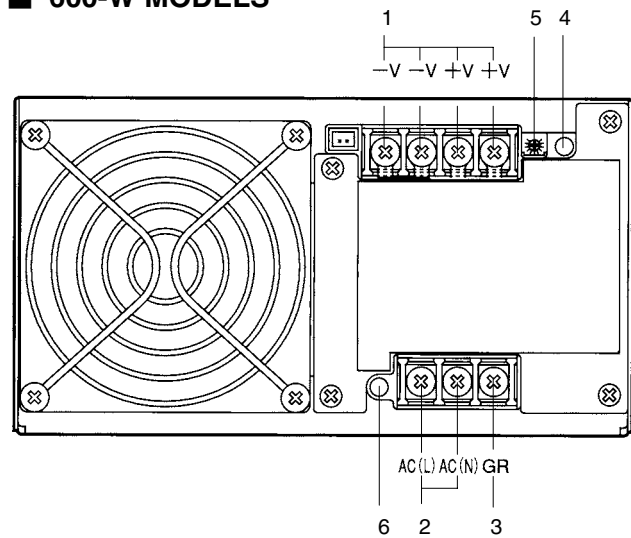

1. **DC Output Terminals:** Connect the load lines to these terminals.
2. **Input Terminals:** Connect the input lines to these terminals.
Note: A fuse is inserted into the AC (L) side.
3. **Ground Terminal (GR):** Connect a ground line to this terminal.
4. **Output Indicator (DC ON):** Lights while a Direct Current (DC) output is ON.
5. **Output Voltage Adjuster (V.ADJ):** It is possible to increase or decrease the output voltage by 10%.
6. **Protection-ON Alarm Indicator:** The red indicator will be lit if the overvoltage (for a 300-/600-W model) or overheat protection (for a 600-W model) circuit is triggered. This indicator will also be lit when overcurrent (for a 600-W model) is detected.

Precautions

! WARNING

Do not touch the S8PS or heat radiation fin while the power is being supplied or immediately after the power is turned OFF. Otherwise, a skin burn may result from the hot Switching Power Supply or radiator.

■ MOUNTING

- When mounting the power supply, allow space for adequate air flow around it – to improve and maintain the reliability of the power supply over a long period of time. The power supply is designed to dissipate heat through natural air-flow.
- Omron recommends mounting the power supply to a metal plate.
- Forced air-cooling is recommended.

■ GENERATING OUTPUT VOLTAGE (±)

An output of ± can be generated by using two Power Supplies as shown below, because the Power Supply produces a floating output.

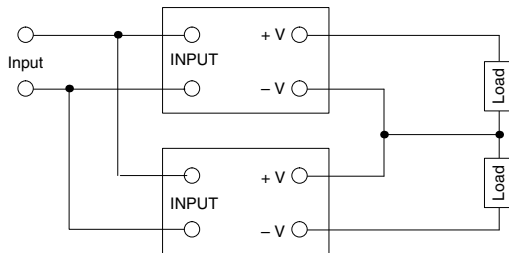

■ SERIES OPERATION

Only models with power ratings of 100/150 W allow series operation.

As shown in the following diagram, the output voltage from each Switching Power Supply can be added.

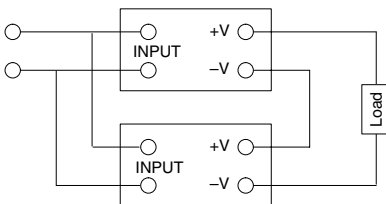

■ PARALLEL OPERATION

Only 300- and 600-W models can be in parallel operation provided that they are operated under 90% of the ratings. Do not operate any other models in parallel.

Make sure that the thickness and the length of all wires connected to the load are the same to ensure that the wires will have no voltage drop differences.

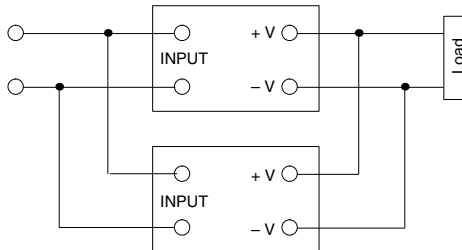

■ FAN REPLACEMENT

The service life of the fan is approximately 50,000 hours (at 25°C). The service life varies, however, depending on the ambient temperature or other surrounding environmental conditions such as dust. As a preventive maintenance measure, replace the fan within two years if it is used at an ambient temperature of 40°C.

Fans are available as replacements.

Model: S82Y-JFAN

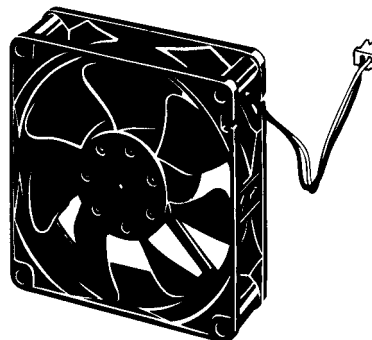

Fan Set:

Fan (above), four M4 x 35 sems screws, instruction sheet, and packing case>

Replace the fan as shown in the following illustration.

