

# Hazardous Location GRP Strobe Light

Model WV450XD and WV450XE



## GLASS REINFORCED POLYESTER DESIGN FOR LOW MAINTENANCE AND CORROSION RESISTANCE

- 21 Joule Unit available
- Seven available lens colors: Amber, Blue, Clear, Green, Magenta, Red and Yellow
- 316 stainless steel mounting bracket included
- Available voltages ( $\pm 15\%$ ):  
21J – 110VAC and 220VAC only
- IP66
- Corrosion-resistant GRP  
(Glass Reinforced Polyester)
- Included dome guard
- M20 entries standard
- Strobe tube life of 10,000 hours
- Body color natural black as  
standard - other colors available
- Zone rated, IECEx, ATEX  
Ex d IIB +H2 T3-T4  
Ex de IIB +H2 T3-T4

The Federal Signal model WV450X is ideally suited for explosive atmospheres and harsh environments. It is designed to serve the demanding needs of offshore marine and land based industrial applications. The housing is made of corrosion-resistant components, which dramatically reduces the cost of long-term maintenance.

The WV450X utilizes all of the latest techniques in non-metallic housing construction. The body of the product is comprised of Glass Reinforced Polyester (GRP) and 316 stainless steel hardware. The use of GRP in the design improves corrosion resistance and reduces weight as compared to traditional metal housings. The GRP construction also saves time and money over the life of the product by reducing or, in most cases, completely eliminating the need to perform regular field inspections of the flame path.

The WV series comes standard with metric entries, a 316 stainless steel dome guard and a 10,000 hour rated strobe tube. There are two versions of the WV450X. The flameproof “d” versions come standard with a 316 stainless steel mounting brackets and two M20 entries for field cable gland connections. The increased safety “e” versions have the added feature of a terminal chamber with three M20 entries. The increased safety design allows for quick field termination and pass-through wiring.



Model	Operating Voltage	Maximum Operating Current	Joule Units	Temperature Code at 55°C	Flash Rate	Lamp Life Hrs.
WV450	110VAC	0.75A	21	T3	60	10,000
	220-248VAC	0.50A	21	T3	60	10,000

Specify color: (A) Amber, (B) Blue, (C) Clear, (G) Green, (M) Magenta, (R) Red or (Y) Yellow



# HAZARDOUS GRP STROBE (WV450XD/WV450XE)

## SPECIFICATIONS

	Effective Candela Peak	Average Effective Candela on HV	Peak Intensity Candela	Actual Output Joules
21 Joules	393	297	357,700	21.5
Glass Color Transmission				
Red <.81	Amber <.48	Yellow <.85	Blue <.12	Green <.52

Terminals: Ex d: (DC) 4 way block (2 in, 2 out)  
(AC) 6 way block (3 in, 3 out)  
Ex de: 3 position dual pole terminal block

Cable Entries: Ex d: 2 entries - M20 x 1.5  
Ex de: 3 entries - M20 x 1.5

Operating Temperatures:  
"d" version without terminal chamber  
ATEX -55°C to 55°C (-67°F to 131°F)  
IECEX -20°C to 55°C (-4°F to 131°F)

"e" version with terminal chamber  
ATEX -20°C to 55°C (-40°F to 131°F)  
IECEX -20°C to 55°C (-4°F to 131°F)

Mounting: Via 316 stainless steel bracket  
Exterior Dome: Toughened glass  
Guard: 316 stainless steel  
External Fasteners: 316 stainless steel

Net/Shipping Weight:  
WV450XD  
Net 3.23 Kg (7.1 lbs.)  
Shipping 3.88 Kg (8.6 lbs.)

WV450XE  
Net 3.9 Kg (8.6 lbs.)  
Shipping 4.54 Kg (10 lbs.)

Shipping Dimensions: 19 x 22 x 47 cm (7.5 x 9 x 18.5 in.)  
ATEX Certificate Number DEMKO 06 ATEX 0425693X  
Note: Covers 10, 15 and 21 Joules

IECEX Certificate Number IECEX UL 06.0010X

Note: Covers 10 and 15 Joules only  
Certification Marking ("d" only version) Ex d IIB + H2 T3-T4 @ -55°C ≤ Tamb ≤ 55°C

Certification Marking ("de" version) Ex de IIB + H2 T3-T4 @ -20°C ≤ Tamb ≤ 55°C

Ingress Protection (IP) Rating IP66

### WV450XD

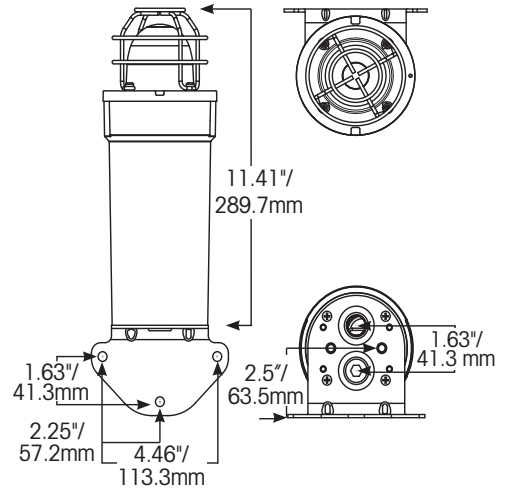

### WV450XE

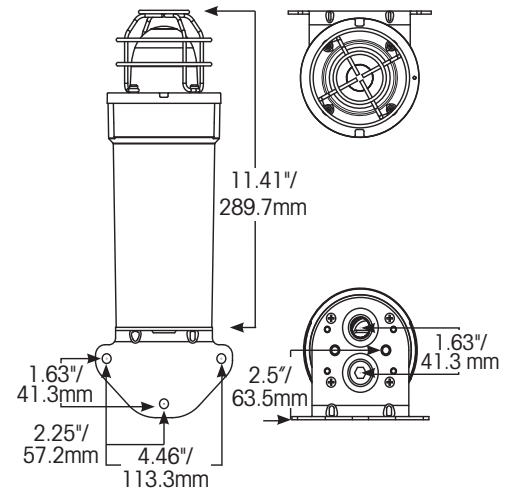

## HOW TO ORDER

<b>WV450X</b>	<b>D</b>	<b>21</b>	<b>220</b>	<b>R</b>	<b>00</b>	<b>COLORS</b>	<b>SPECIAL FEATURES</b>
<b>TYPE</b>						<b>A</b> - Amber <b>B</b> - Blue <b>C</b> - Clear <b>G</b> - Green <b>M</b> - Magenta <b>R</b> - Red <b>Y</b> - Yellow	<b>00</b> None -- Retrofit Plate -- Body Colour
<b>PROTECTION</b>	<b>D</b> Flameproof "d" Increased Safety <b>E</b> "e" terminal box	<b>RATING</b>	<b>21</b> 21 Joule	<b>VOLTAGES ±15%</b>	<b>220</b> 21J – 110VAC and 220VAC only		